



## SCH-170165 ABA SIDE TABLE ASSEMBLY INSTRUCTION

### PARTS INCLUDE :

1. 1 - Top
2. 4 - leg

### HARDWARE INCLUDE :

- A. 16 – Allen Bolt
- B. 16– Lock Washer
- C. 1 – Allen Key

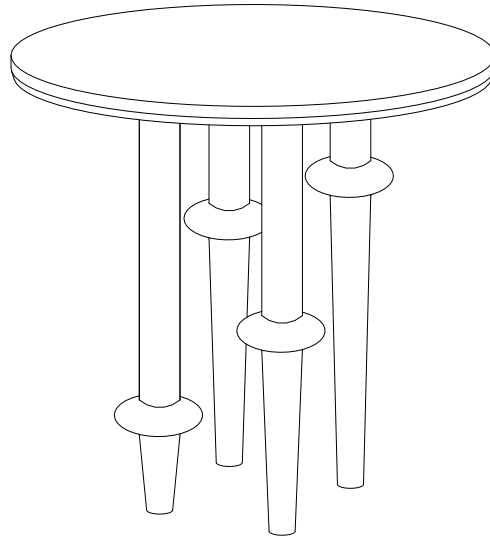

### PARTS :

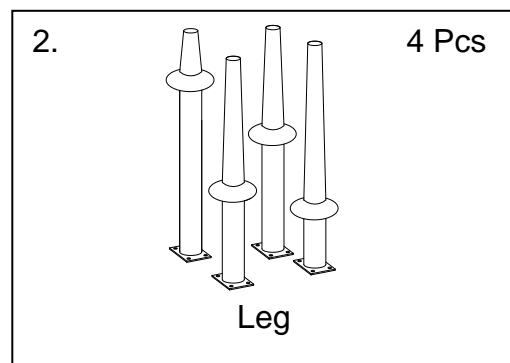
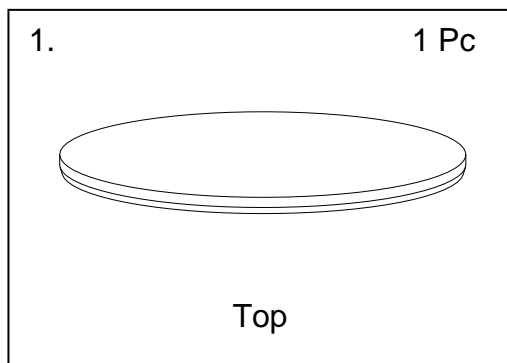

### HARDWARE :

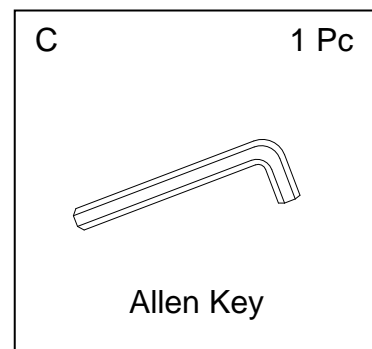
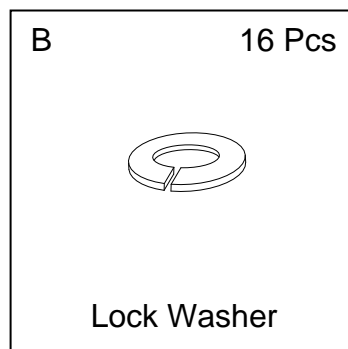
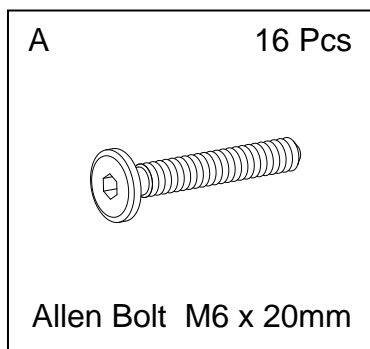



## SCH-170165 ABA SIDE TABLE

### ASSEMBLY INSTRUCTION

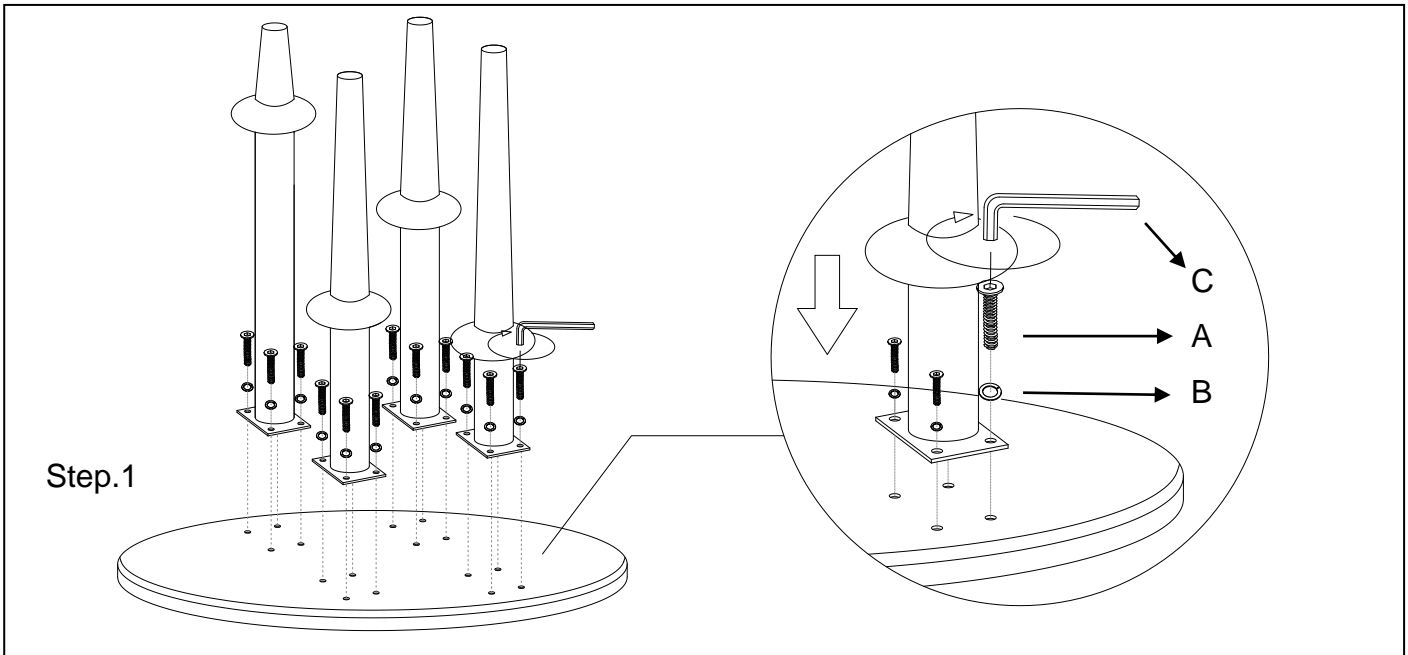

- Step.1
- Carefully lay the Table Top (1) upside down on a clean protected surface (the shipping box provides an ideal work surface).
  - Attached the legs by inserting the bolts into the pre mounted insert nut at the mounting plate through lock washer (B) and the metal mending plate. Tighten securely using Allen key.

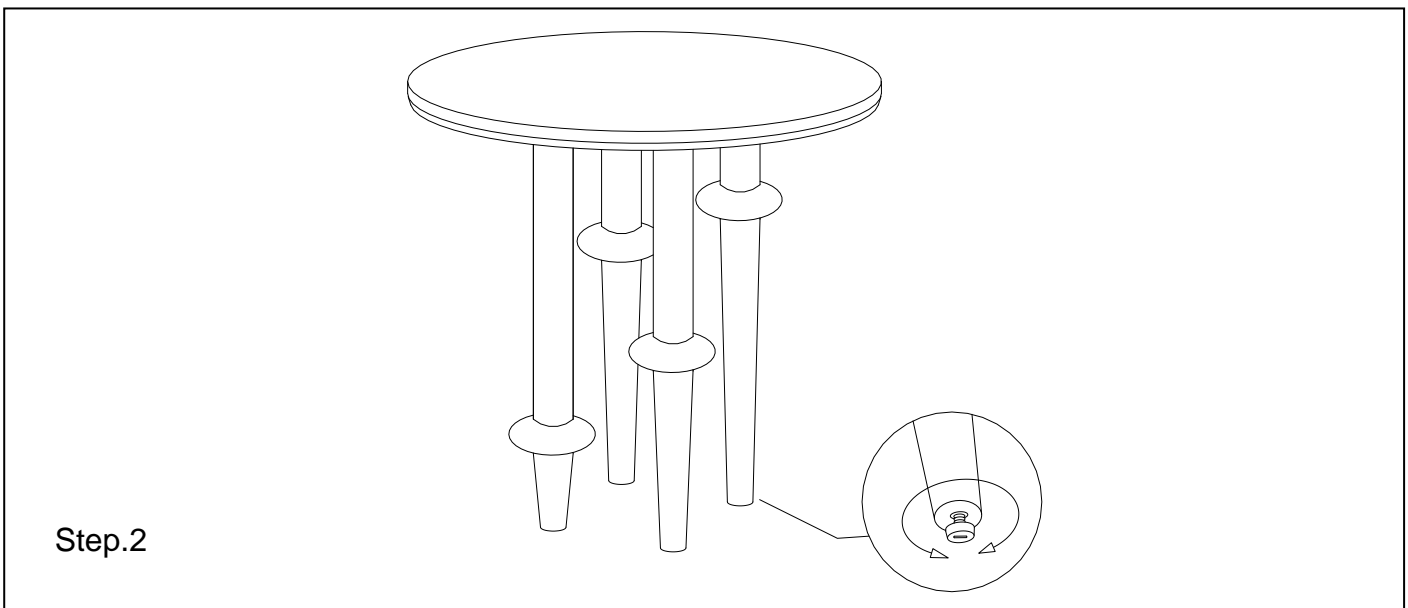

- Step.2
- If the floor is uneven adjust the levelers located at the underside of the Leg, to do this lift Up the side that need to be elevated to provide access to the levelers, turn the leveler until adequate contact with the floor.