



LEONA DRESSER ASSEMBLY INSTRUCTION

HARDWARE INCLUDE :

1. 2 Anti Tip Kit
 - A. 4 -Small Screw
 - B. 4- Large Screw
 - C. 4-Bracket
 - D. 2-Retention Belt

PARTS INCLUDE :

- E. 1 – Body
- F. 4 – Feet



PARTS :

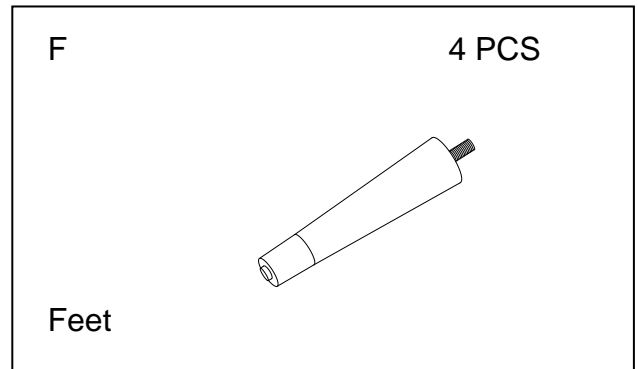
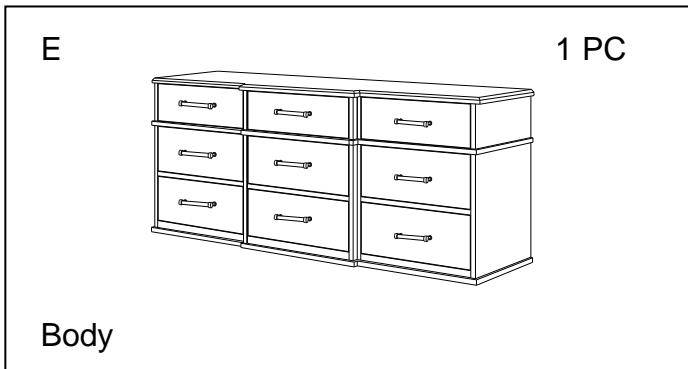

HARDWARE :

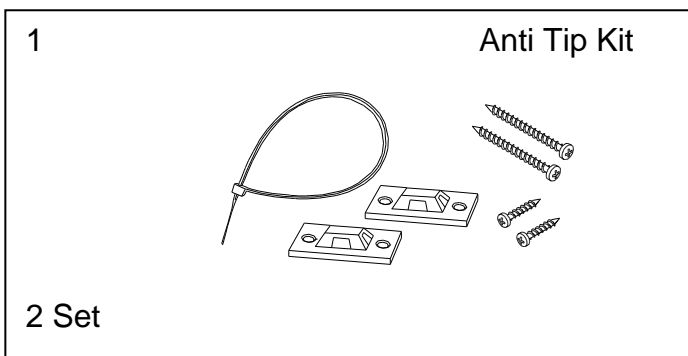

TOOLS REQUIRED:

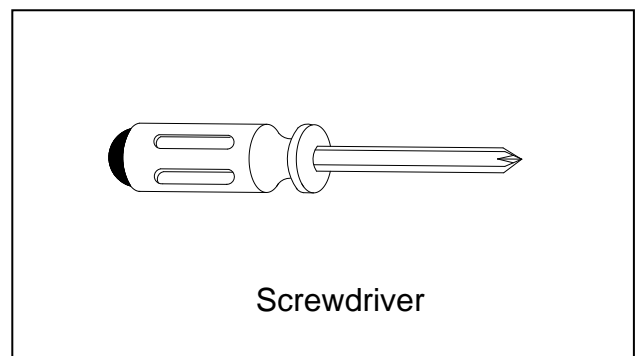



LEONA DRESSER ASSEMBLY INSTRUCTION

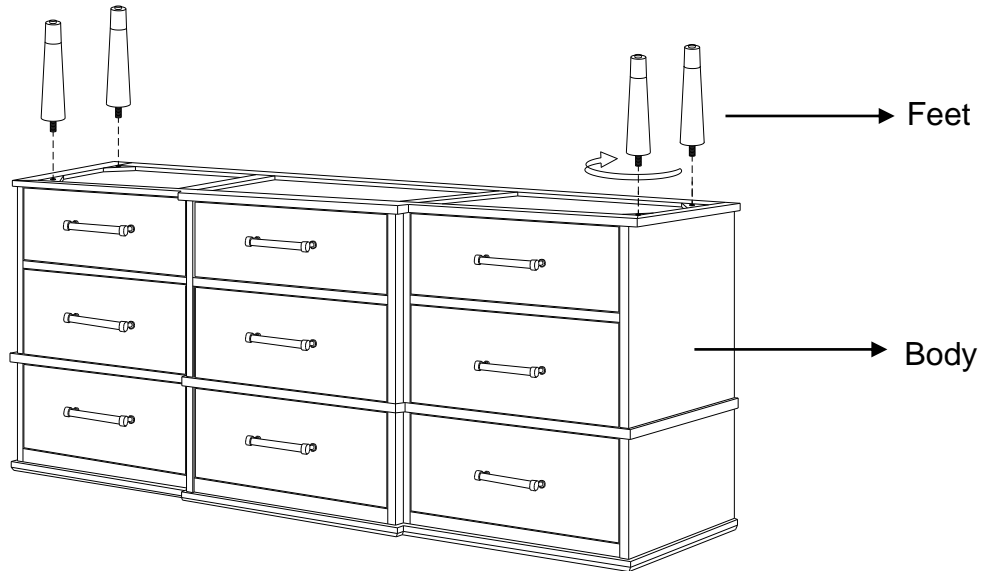

STEP 1

- Put the dresser top side down on a clean protected work surface where the unit can be assemble.
- Insert the pre-mounted bolt insert of the feet into the female insert nut of the base and turn the feet clockwise until it get light.



STEP 2

- If the floor is uneven adjust the levelers located at the underside of the Feet, to do this lift Up the side that need to be elevated to provide access to the levelers, turn the leveler until adequate contact with the floor.



LEONA DRESSER ASSEMBLY INSTRUCTION

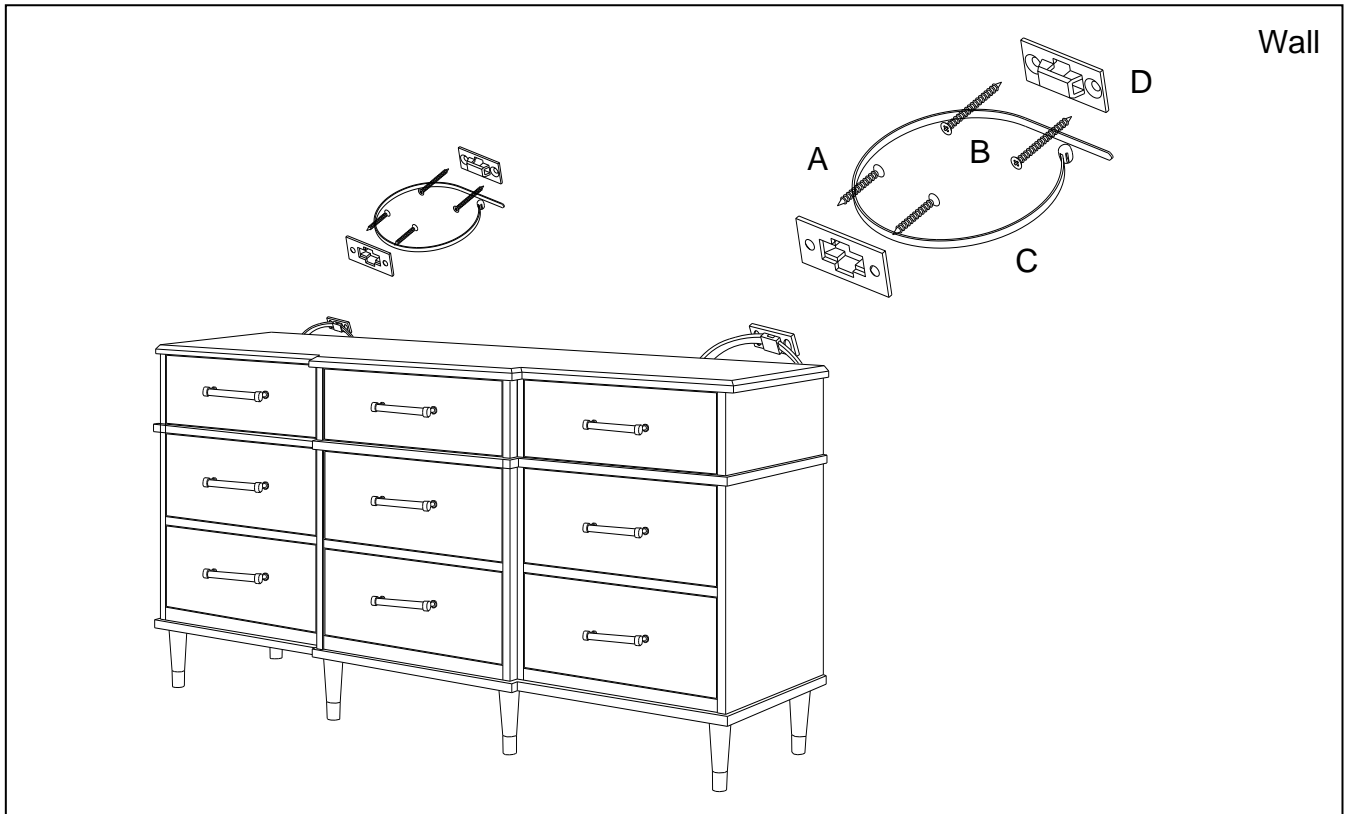

Attach the Brackets (C) horizontally to the top of the back of the Dresser using the Small Screws (A).

Screw the remaining Brackets (C) vertically 1 inch below the brackets attached to the Dresser using the large screws (B). The Large Screws (B) should be screwed into a stud in the wall. Align the Brackets vertically and string in the Retention Belt (D). Confirm Strap is securely laced and locked.