



ASSEMBLY INSTRUCTION

Hardware Include :

No	Part	Description	Qty
1		JCBC Bolts 45 mm	8 pcs
2		Flat Washer	12 pcs
3		Spring Washer	12 pcs
4		JCBC Bolts 60 mm	4 pcs
5		Allen Key 4	1 pc

Parts Include :

No	Description		Qty
A	Frame Connector		1 pc
B	Round Top Panel		1 pcs
C	Frame Top Support		1 pcs

HOW TO ASSEMBLY:

Require two persons to perform this assembly process.

STEP 1:

- Assemble the Frame Connector (A) with Frame Top Support (C) using the JCBC Bolt M6 x 60 mm (4) with Flat Washer (2) and Lock Washer (3). Securely tighten with Allen Key 4 (5) as provided;

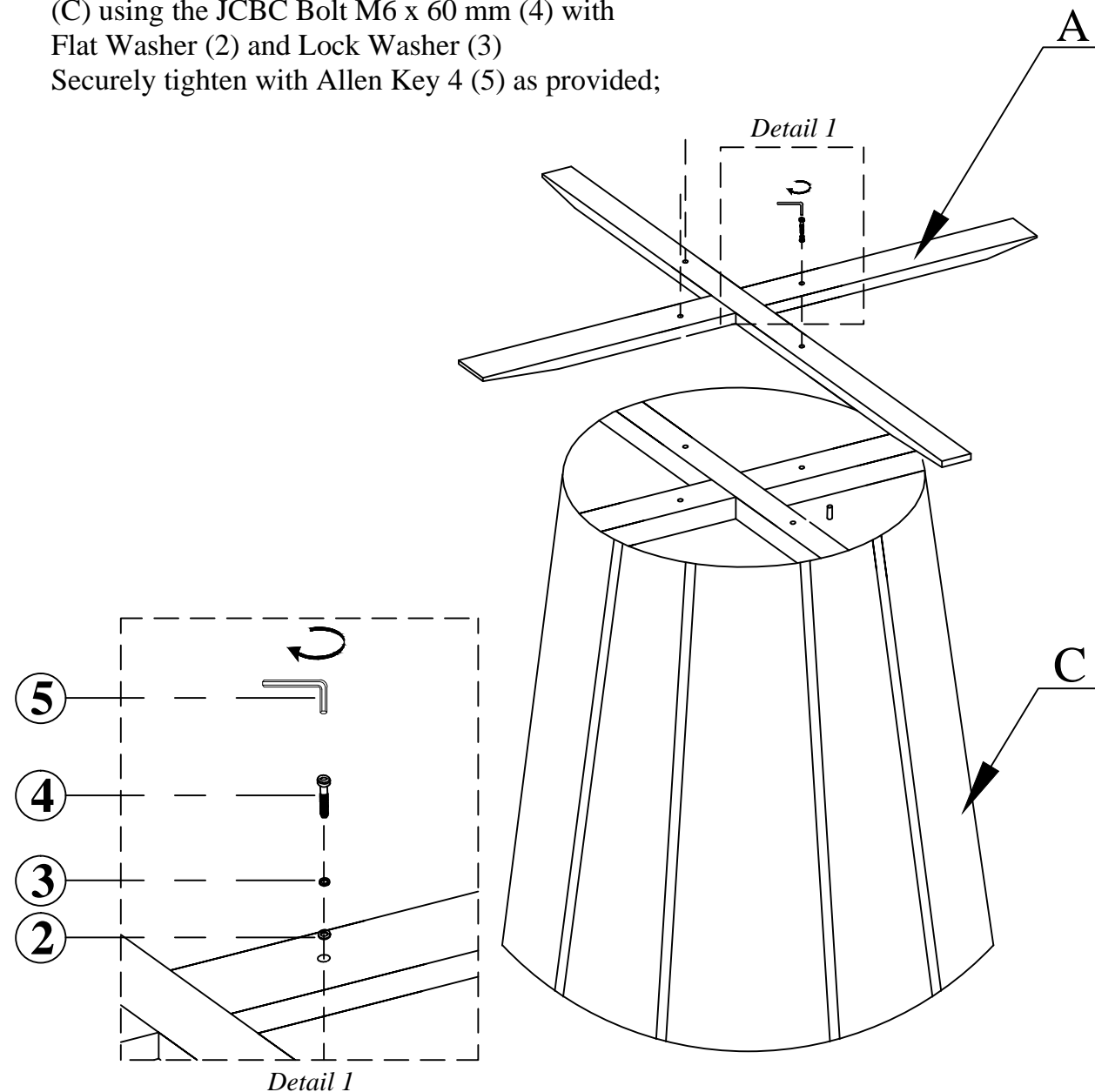

STEP 2:

- Assemble the Round Top Panel (B) with Frame Top Support (A) using the JCBC Bolt M6 x 45 mm (1) with Flat Washer (2) and Lock Washer (3). Securely tighten with Allen Key 4 (5) as provided;
- Make sure the dowel is installed when installing top panels and Frame Top Support.
- If the floor uneven the levelers located at the underside of the Leg, to do this lift Up the side that need to be elevated to provide access to the levelers, turn the leveler until adequate contact with the floor as shown *detail 4*.

