

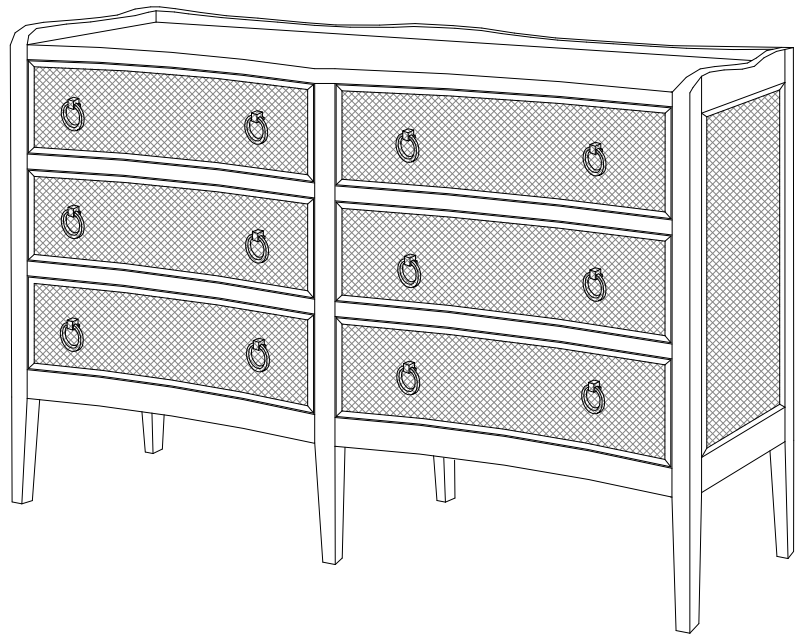

NAOMI CHEST ASSEMBLY INSTRUCTION

HARDWARE INCLUDE:

1. 2 - Anti Tip Kit
 - A. 4 -Small Screw
 - B. 4- Large Screw
 - C. 4-Bracket
 - D. 2-Retention Belt



HARDWARE :

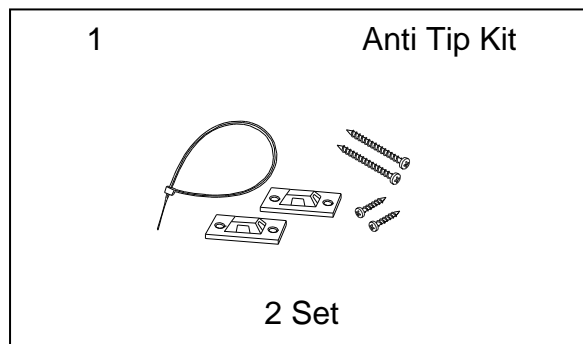



NAOMI CHEST ASSEMBLY INSTRUCTION

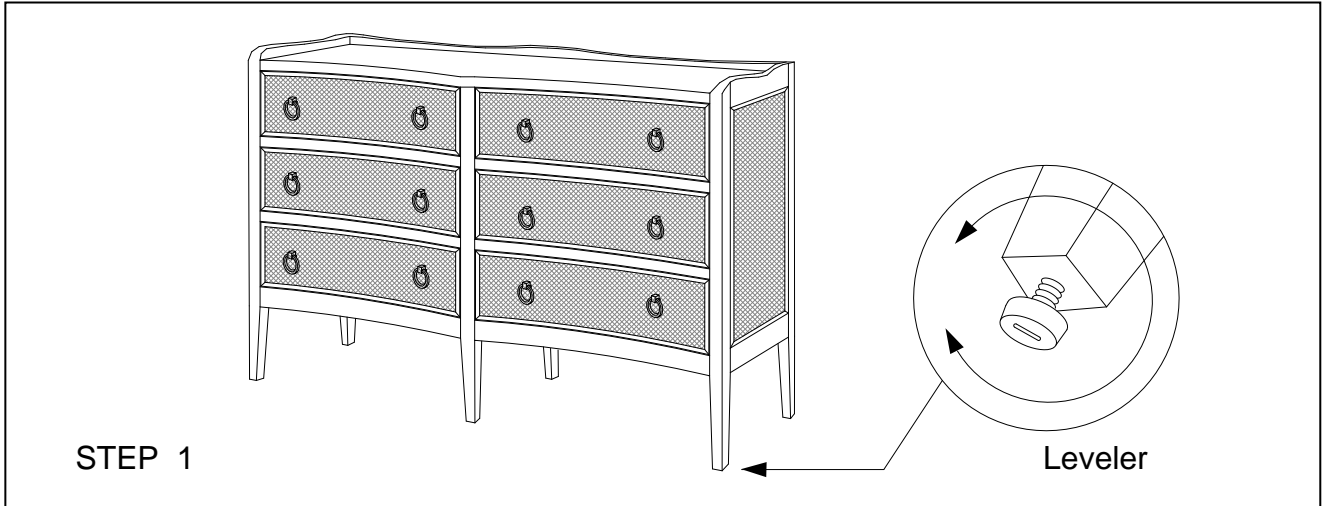

STEP 1

- If the floor is uneven adjust the levelers located at the underside of the Leg, to do this lift Up the side that need to be elevated to provide access to the levelers, turn the leveler until adequate contact with the floor.

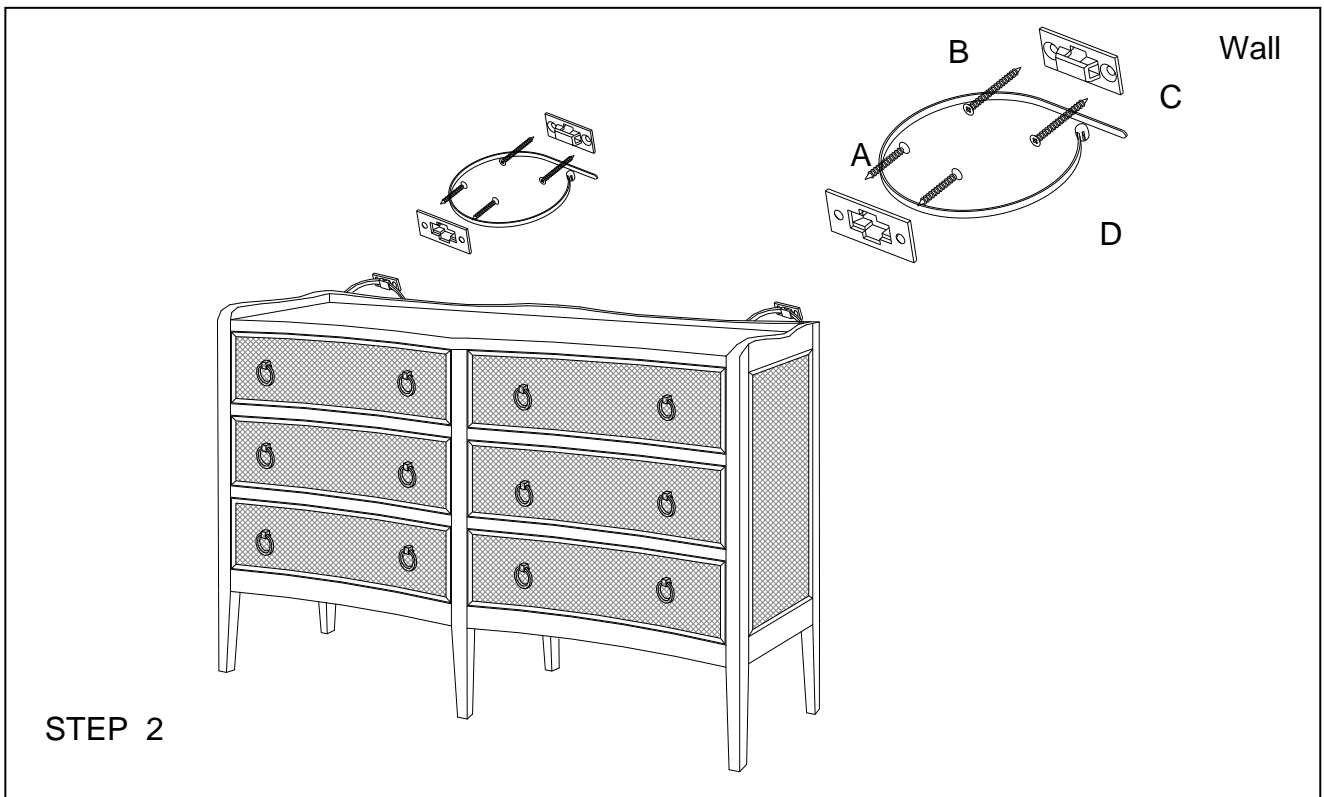

STEP 2

Attach the Brackets (C) horizontally to the top of the back of the Chest using the Small Screws (A). Screw the remaining Brackets (C) vertically 1 inch below the brackets attached to the Chest using the large screws (B). The Large Screws (B) should be screwed into a stud in the wall. Align the Brackets vertically and string in the Retention Belt (D). Confirm Strap is securely laced and locked.