

## RHETT CABINET DOUBLE ASSEMBLY INSTRUCTION

**PARTS INCLUDE :**

1. 1-Body Rhett Cabinet
2. 4-Adj. Shelf

**HARDWARE INCLUDE :**

- A. 16 - Metal Supports
- B. 16 - Screw JP.
- C. 2- Anti Tip Kit
  - I. 4- Small Screw
  - II. 4- Large Screw
  - III. 2- Bracket
  - IV. 2- Retention Belt
- D. 1 - L Screwdriver

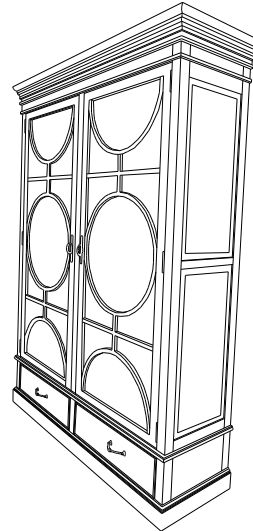

**PARTS:**

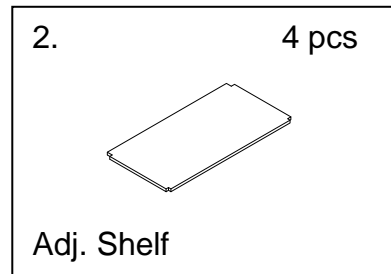
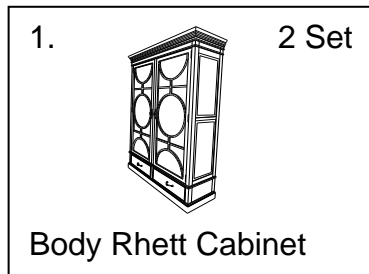

**HARDWARE:**

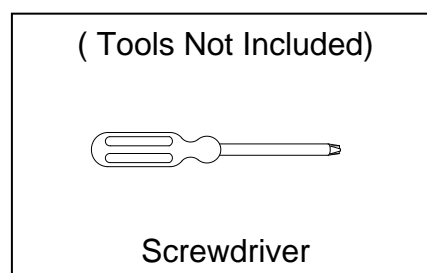
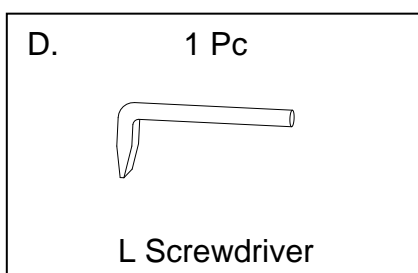
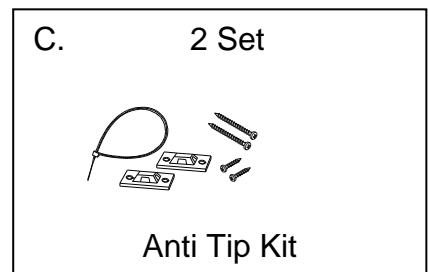
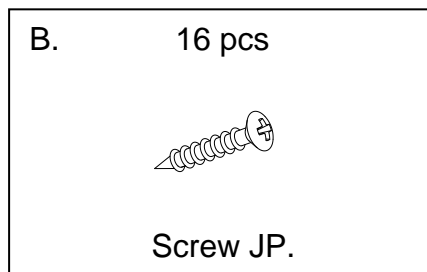
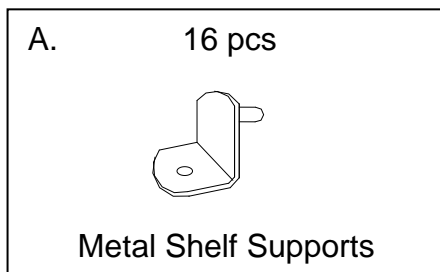



## RHETT CABINET DOUBLE ASSEMBLY INSTRUCTION

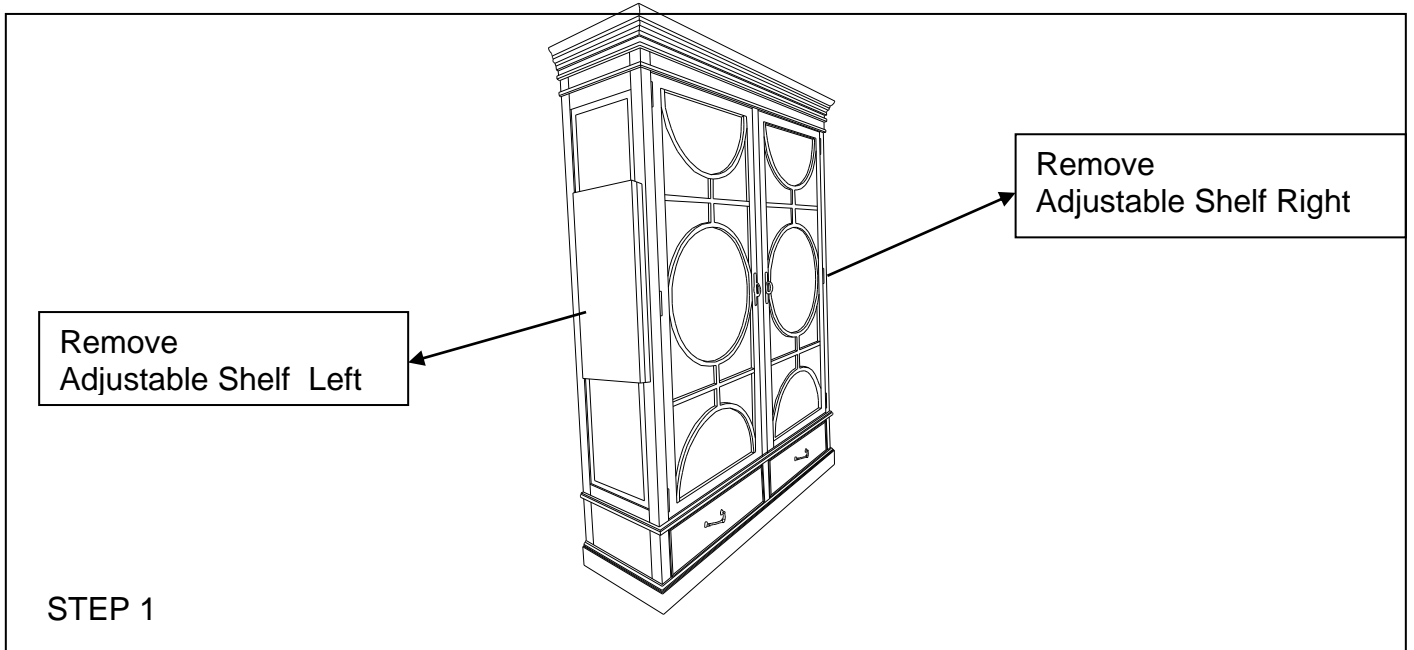

- Remove Adjustable shelves from the body.

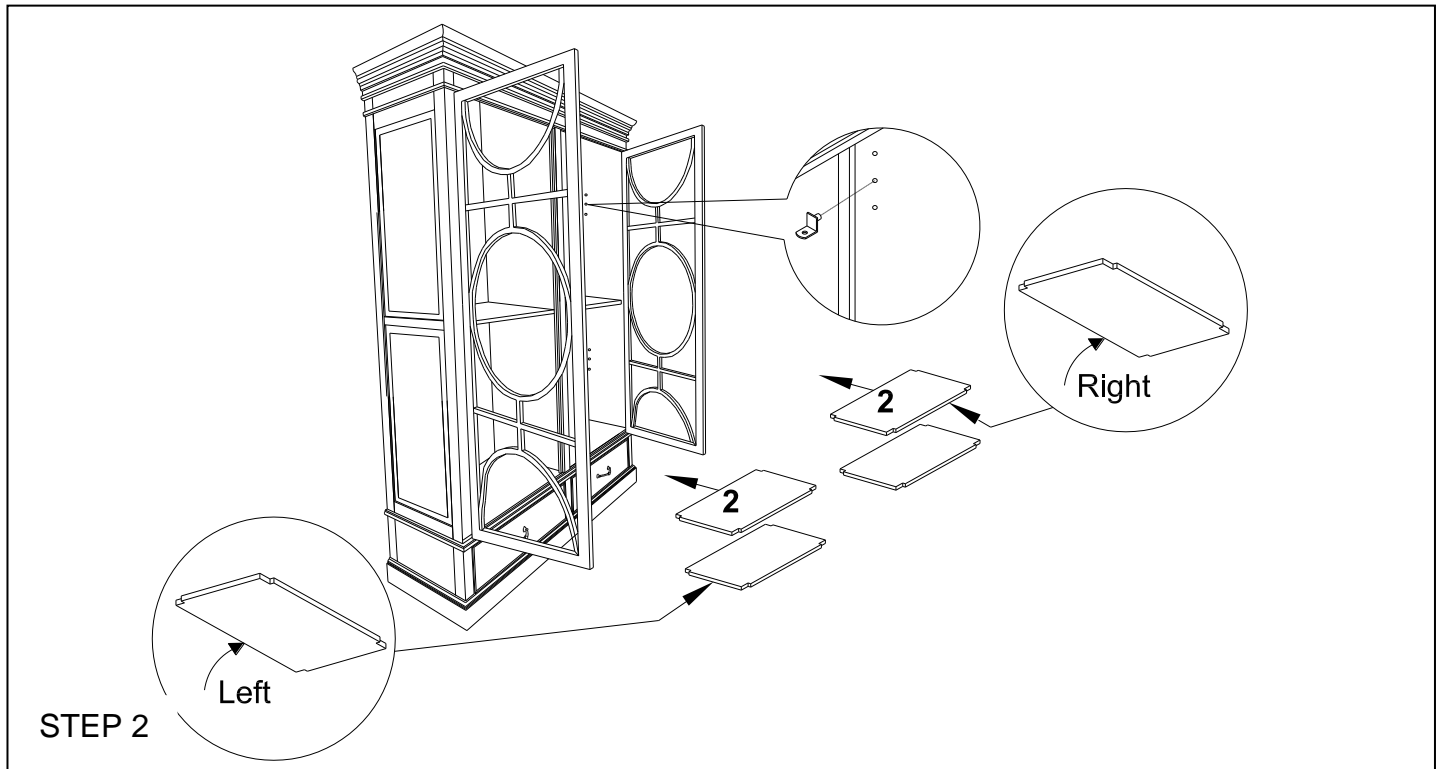

- To Install adjustable shelves, insert stem of shelf supports into holes in end panel, as shown. Rest the shelf on the shelf supports, and screw.



## RHETT CABINET DOUBLE ASSEMBLY INSTRUCTION

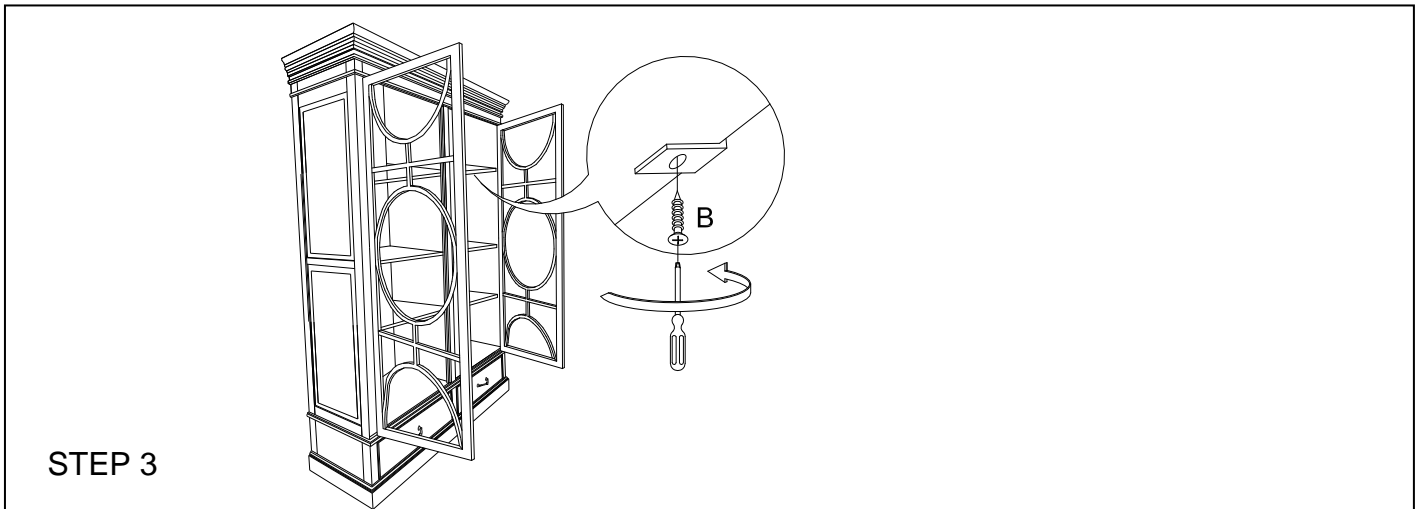

-To Reposition adjustable shelves, un-screw the shelves from shelf supports, then carefully lift shelves up and out of the case. Inserts stem of shelf supports into holes in end panel, as shown. Rest the shelf on the shelf supports, and reinstall screws.

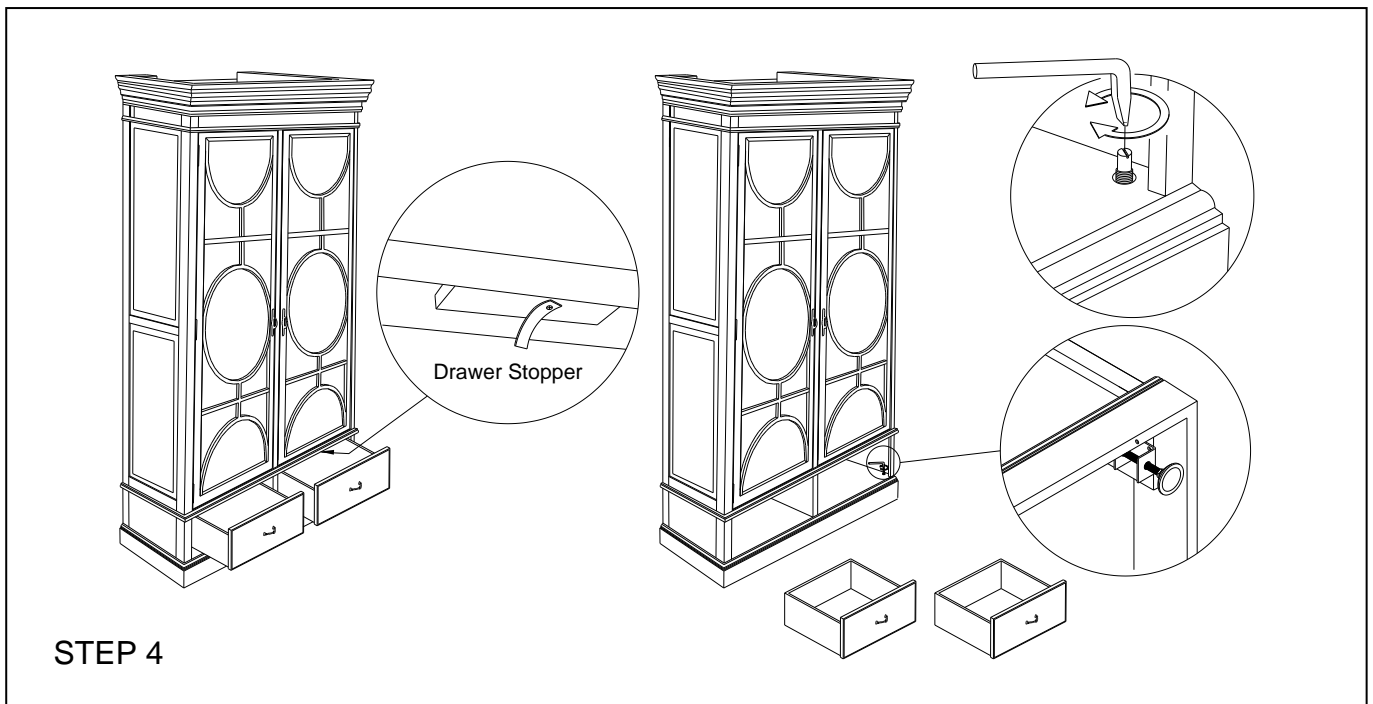

- If the floor is uneven remove the bottom drawer and adjust the leveler with a slotted L Screwdriver through the hole of the base, (please see sketch) turn the leveler until adequate contact with the floor.



## **RHETT CABINET DOUBLE ASSEMBLY INSTRUCTION**

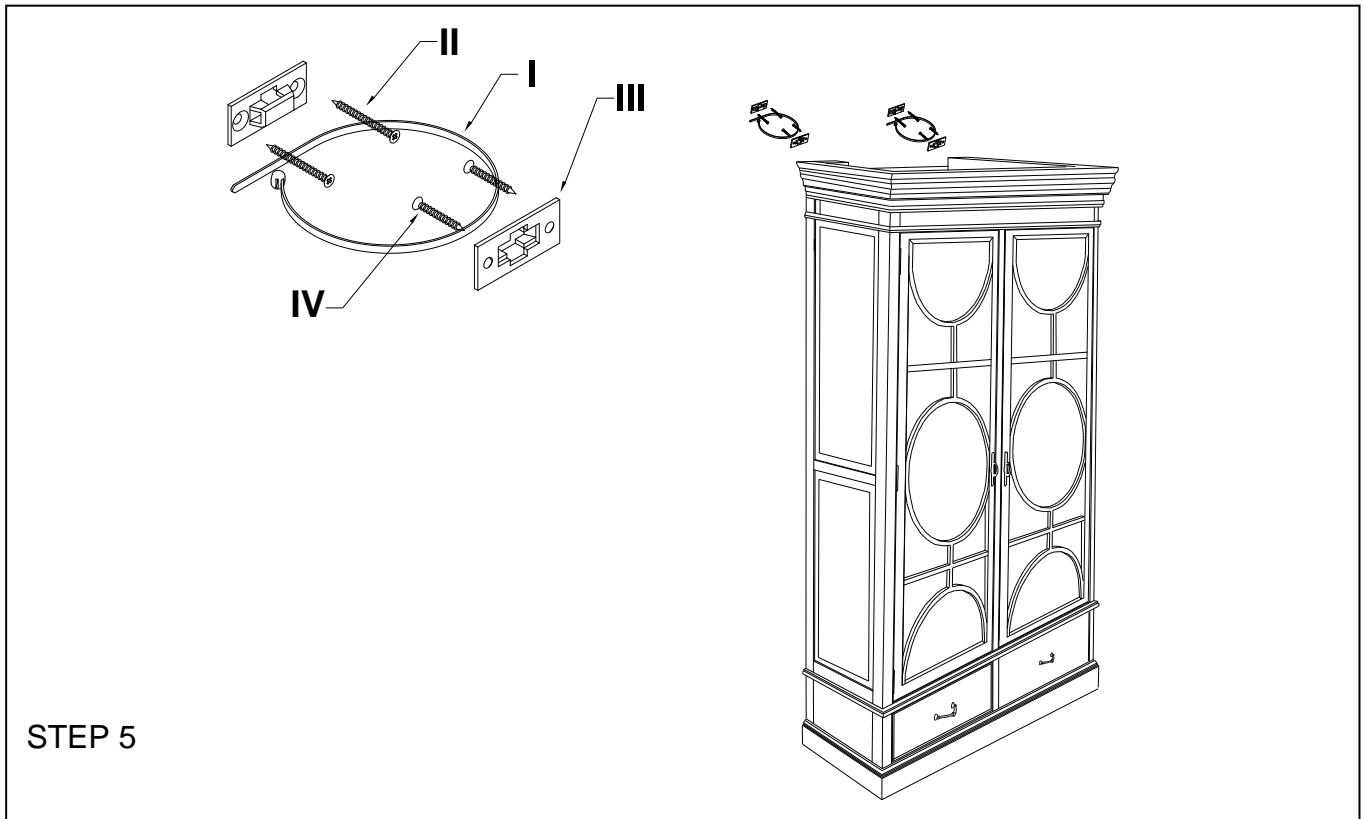

**STEP 5**

Attach 2 Brackets (III) horizontally to the top corners of the Unit using the Small Screws (I). Screw the remaining Brackets (III) into the wall vertically 1 inch below the previously installed brackets using the Large Screws (II). The Large Screws (II) should be screwed into a stud in the wall. Align the brackets vertically and string in the Retention Belt (IV). Confirm Strap is securely laced and locked.

