



SCH-167050 RODERICK DINING TABLE ASSEMBLY INSTRUCTION

Hardware Include :

No	Part	Description	Qty
A		Flat Washer M8	20 pcs
B		Spring Washer M8	20 pcs
C		JCBC Bolts M8 x 30 mm	20 pcs
D		Allen Key 5	1 pc

Parts Include :

No	Description	Qty
1	Top panel	1 pc
2	Leaf Top	1 pc
3	Side Legs Assembly	2 pcs
4	Center Legs	2 pcs
5	Stretcher	2 pcs

No	Part	Description	Qty
E		Flat Washer M6	4 pcs
F		Spring Washer M6	4 pcs
G		JCBC Bolts M6 x 60 mm	4 pcs
H		Allen Key 4	1 pc

How to Assembly:

1. Cover the assembly area with a clean soft blanket or pad to protect the product from scratches and dents while being assembled;
2. Attach the Side Legs Assembly (3) with Top panel (1) using the JCBC Bolt M8 x 30 mm (C) with Flat Washer M8 (A) and Spring Washer M8 (B) Securely tighten with Allen Key 4 (D) as provided. Assembly in the inverted position for easy installation. Do not place the extension leaves before the top is secured as shown FIG.1;

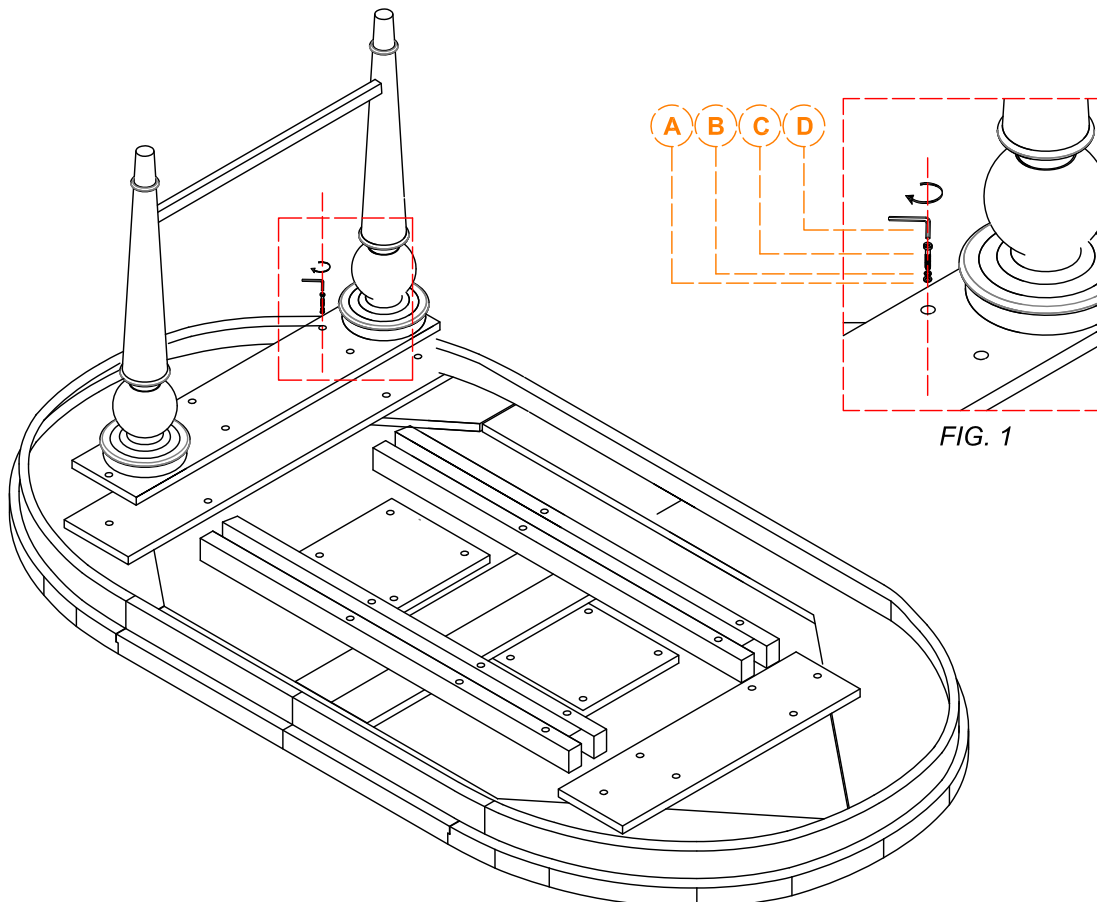

FIG. 1

3. Attach the Stretcher (5) with the Center Legs (4) using the JCBC Bolt M6 x 60 mm (G) with Flat Washer M6 (E) and Spring Washer M6 (F) Securely tighten with Allen Key 4 (H) as provided (FIG.2);

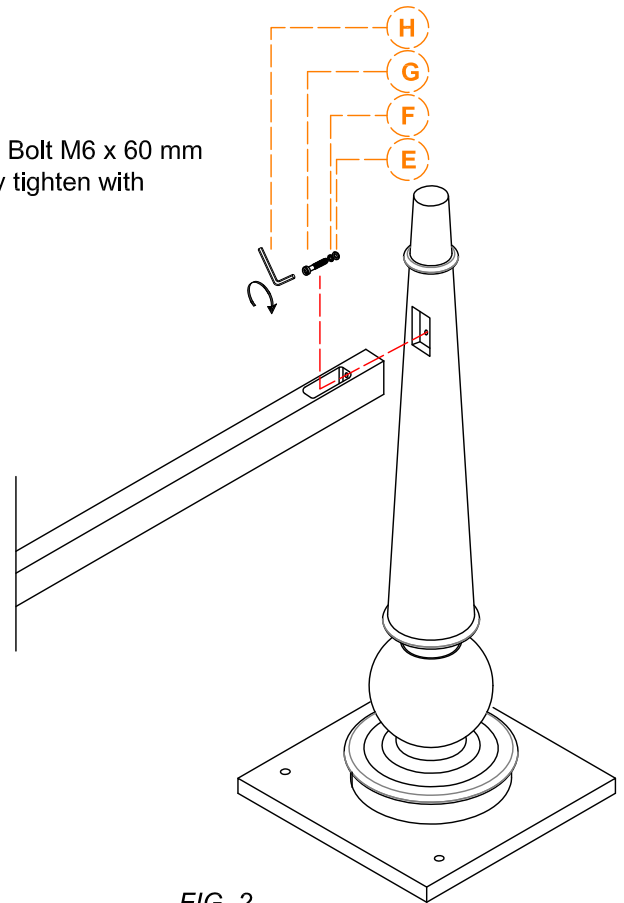

FIG. 2

4. Attach the Stretcher (5) with the Side Legs Assembly (3) using the JCBC Bolt M6 x 60 mm (G) with Flat Washer M6 (E) and Spring Washer M6 (F) Securely tighten with Allen Key 4 (H) as provided (FIG.3);
5. Attach the Center Legs (4) with Top panel (1) using the JCBC Bolt M8 x 30 mm (C) with Flat Washer M8 (A) and Spring Washer M8 (B) Securely tighten with Allen Key 5 (D) as provided (FIG.4);

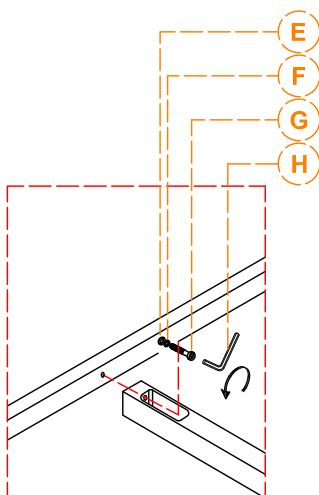

FIG. 3

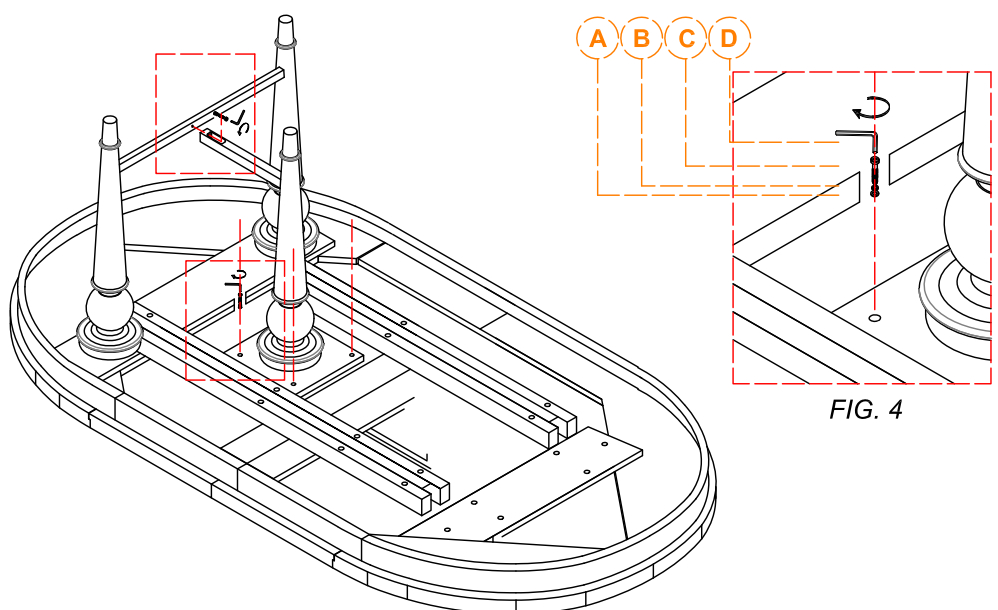

FIG. 4



6. Open sliding sideways before pairing leaves to body assemblies. Using the table leaves.
Open the metal lock under the table top as shown in the diagram. Pull out the table top;
7. Place the leaves on the metal slides. Push in the top table, and lock them using metal lock.
8. If the floor uneven the levelers located at the underside of the Leg, to do this lift Up the side that need to be elevated to provide access to the levelers, turn the leveler until adequate contact with the floor (FIG.5).

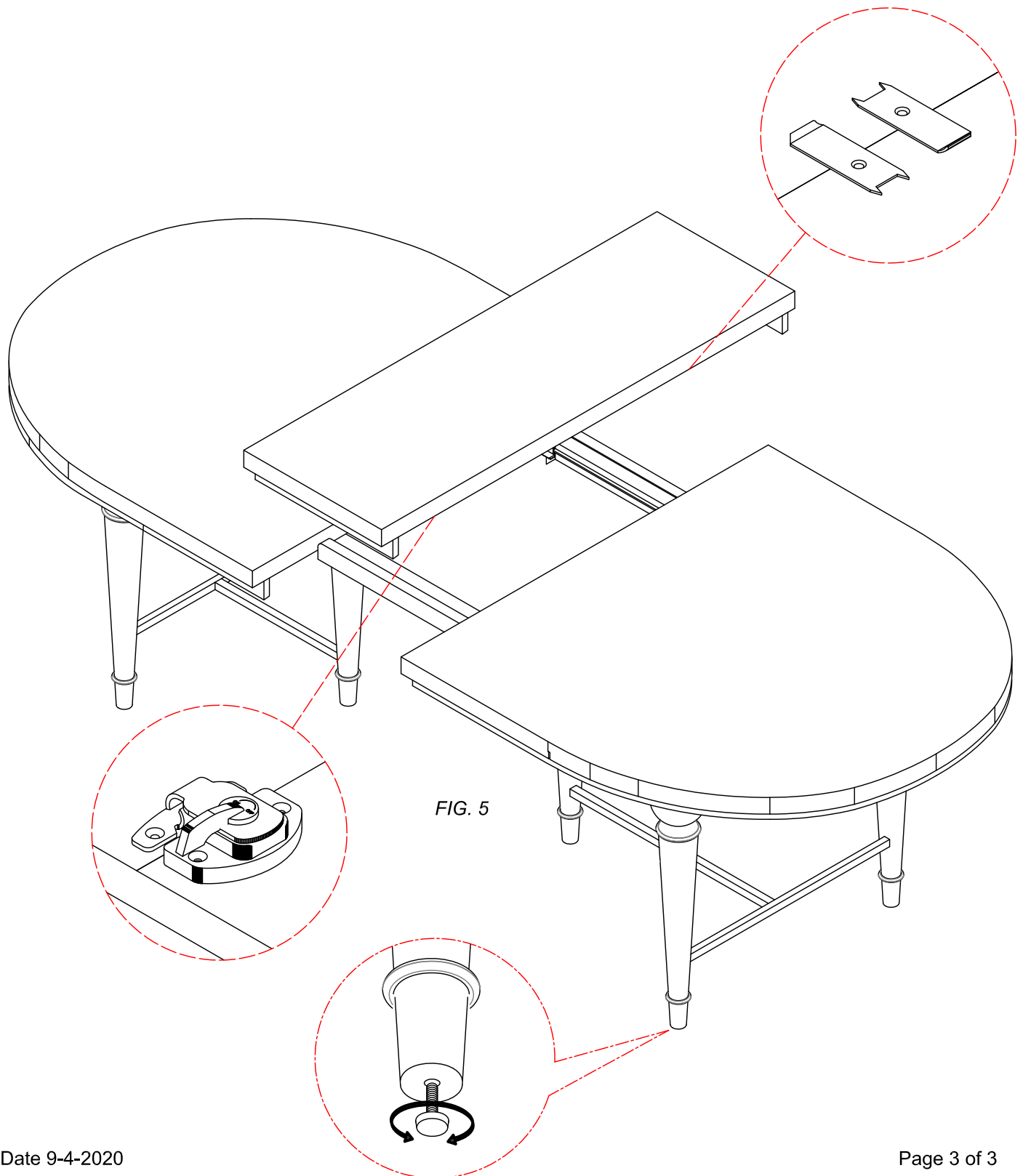

FIG. 5